



---

## SKYLIGHT APPLICATION

Submittal requirements for Skylight Application are listed below. Please include the following items:

### 1) PLANNING APPLICATION: Skylight Application

- Complete all sections (incomplete applications will delay processing time)
- Include all required plans/drawings/calculations listed in the application
- Homeowner's signature required
- If property is located in a homeowners association, complete HOA Approval Form at [http://www.cerritos.us/RESIDENTS/\\_pdfs/hoa\\_approval\\_form.pdf](http://www.cerritos.us/RESIDENTS/_pdfs/hoa_approval_form.pdf)

If you have any questions, please call the Planning Division at (562) 916-1201.

### 2) BUILDING PERMIT APPLICATION

- Complete all sections (incomplete applications will delay processing time)
- Complete Declaration Form
  - If owner-builder, complete columns 1 and 3
  - If contractor, complete columns 2 and 3

If you have any questions, please call the Building & Safety Division at (562) 916-1209.

Submit forms together, with all required plans/drawings, at [https://cerritosca.seamlessdocs.com/f/Application\\_Plan\\_Submittal\\_Form](https://cerritosca.seamlessdocs.com/f/Application_Plan_Submittal_Form)

For more detailed information regarding the process for online submittal, please read the *Planning/Building Interim Electronic Submittal Procedure* at [http://www.cerritos.us/BUSINESSES/\\_pdfs/interim\\_electronic\\_submittal\\_procedure.pdf](http://www.cerritos.us/BUSINESSES/_pdfs/interim_electronic_submittal_procedure.pdf)

---

### 3) BUSINESS LICENSE REQUIREMENT

If you are a contractor, you must have a valid City of Cerritos business license.

Please call the Business License Division at (562) 916-1236 to confirm active status or apply at [http://www.cerritos.us/BUSINESSES/business\\_licenses.php](http://www.cerritos.us/BUSINESSES/business_licenses.php)

For more detailed information regarding the process for online submittal, please read the *Business License Interim Electronic Submittal Procedure* at [http://www.cerritos.us/BUSINESSES/\\_pdfs/interim\\_business\\_license\\_procedure.pdf](http://www.cerritos.us/BUSINESSES/_pdfs/interim_business_license_procedure.pdf)

*The page is intentionally left blank.*



# City of Cerritos

Civic Center • 18125 Bloomfield Avenue  
P.O. Box 3130 • Cerritos, California 90703-3130  
Phone: (562) 916-1201 • Fax (562) 916-1371

## SKYLIGHT APPLICATION

Please print or type

AP# \_\_\_\_\_

### HOMEOWNER'S INFORMATION

Name: \_\_\_\_\_ Phone: \_\_\_\_\_

Address: \_\_\_\_\_

### SKYLIGHT INFORMATION

Manufacturer: \_\_\_\_\_ Model Number: \_\_\_\_\_

ICC Number: \_\_\_\_\_ Size \_\_\_\_\_ X \_\_\_\_\_

**COLOR:**  Bronze

Clear

**STYLE:**  Flat

Dome (maximum dome height is 6")

### DRAWINGS REQUIRED

1. Provide a detail of rafter and joist size and spacing

Are there any rafter cuts?  Yes  No

Are there any joist cuts?  Yes  No

2. Provide a roof plan that indicates the location of the skylight(s).

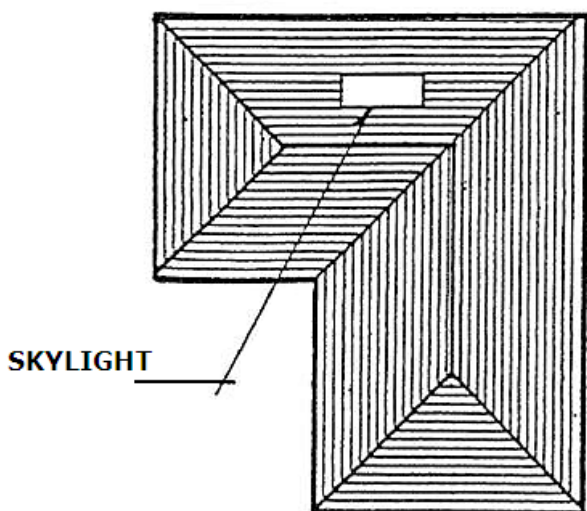

**EXAMPLE ROOF PLAN**

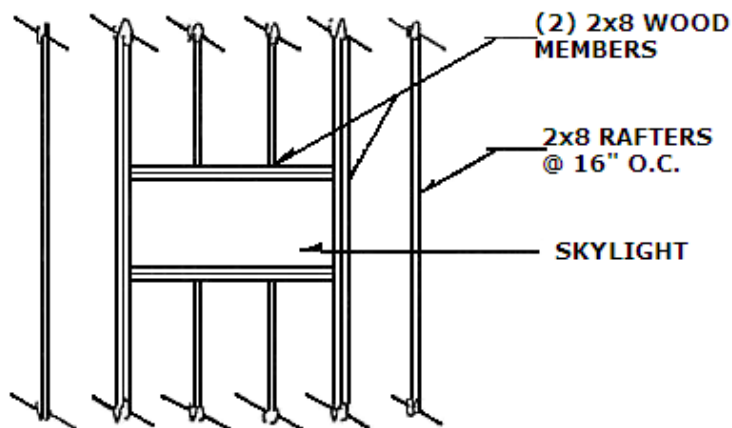

**EXAMPLE FRAMING DETAIL**

*The page is intentionally left blank.*



**City of Cerritos**  
 18125 Bloomfield Avenue  
 Cerritos, CA 90703  
 (562) 916-1209

**Department of Community  
 Development**  
 Building and Safety Division

(For office use only)

Building Permit #: \_\_\_\_\_

Trade Permit #: \_\_\_\_\_

Parent Permit#: \_\_\_\_\_

**Building/Plumbing/Electrical/Mechanical Permit Application**

Applicant's Name: \_\_\_\_\_

Company Name (if applicable): \_\_\_\_\_

Tel. No: \_\_\_\_\_ Email: \_\_\_\_\_ Date: \_\_\_\_\_

Job Site Address: \_\_\_\_\_ Suite: \_\_\_\_\_

Work Description: \_\_\_\_\_

\_\_\_\_\_

Is this an owner-builder project?

Yes, this is an owner-builder project. As the applicant for an owner-building project, you are required to complete columns 1 and 3 of attached Declaration Form.

Is the job site address your primary residence?  Yes  No (If no, an owner-builder project is not permitted, and the owner must contract exclusively with a licensed contractor.)

No, this is not an owner-builder project. Complete columns 2 and 3 of the attached Declaration Form.

Project Valuation: \_\_\_\_\_ APN#: \_\_\_\_\_

Project Size (sq.ft.): \_\_\_\_\_ Buildings on Lot: \_\_\_\_\_ # of Stories \_\_\_\_\_

Construction Types: \_\_\_\_\_ Occupancy Groups: \_\_\_\_\_

**Type of Permit(s) Requested:**  Building  Plumbing  Electrical  Mechanical

**Owner/Business Name:** \_\_\_\_\_

Street Address: \_\_\_\_\_

City: \_\_\_\_\_ State: \_\_\_\_\_ Zip Code: \_\_\_\_\_

Telephone Number: \_\_\_\_\_ Email: \_\_\_\_\_

**Contractor Name:** \_\_\_\_\_ **Company:** \_\_\_\_\_

Street Address: \_\_\_\_\_

City: \_\_\_\_\_ State: \_\_\_\_\_ Zip Code: \_\_\_\_\_

Telephone Number: \_\_\_\_\_ Email: \_\_\_\_\_

License No: \_\_\_\_\_ Class: \_\_\_\_\_ Expiration Date: \_\_\_\_\_

City Business License No: \_\_\_\_\_ Expiration Date: \_\_\_\_\_

**(Please fill out attached Licensed Contractor's Declaration Form)**

**Architect/Engineer Name:** \_\_\_\_\_ **Company:** \_\_\_\_\_

Street Address: \_\_\_\_\_

City: \_\_\_\_\_ State: \_\_\_\_\_ Zip Code: \_\_\_\_\_

Telephone Number: \_\_\_\_\_

License No: \_\_\_\_\_ Class: \_\_\_\_\_ Expiration Date: \_\_\_\_\_

# Building/Plumbing/Electrical/Mechanical Permit Application (continued)

## PLUMBING

Code	Items	Units	Code	Items	Units
03	Backwater Valves	___ Valve(s)	45	Water closet/urinal/bidet	___ Fixture(s)
05	Backflow prevention device/sprinkler	___ Device(s)	47	Water heater	___ W.H.(s)
07	Bathtubs/showers	___ Fixture(s)	49	Water treating equipment (filter, softener)	___ System(s)
11	Clothes washer (tray/standpipe)	___ Fixture(s)	51	Low pressure gas sys. (5 outlets or less)	___ System(s)
13	Dishwashers	___ Fixture(s)	52	Fee for additional outlets >5	___ Outlet(s)
15	Drinking fountain	___ Fixture(s)	53	Medium/high pressure gas system	___ System(s)
17	Floor drains	___ Fixture(s)	54	Additional fee for each outlet	___ Outlet(s)
19	Floor sinks	___ Fixture(s)	55	Gas meter (private)	___ Meter(s)
21	Hose bibbs	___ Fixture(s)	56	Gas regulator	___ Reg(s)
23	Interceptor (clarifier)	___ System(s)	60	Drainage/vent piping repair or alter	___ System(s)
25	Lavatories/sinks	___ Fixture(s)	62	Greywater system	___ System(s)
26	Miscellaneous fixture	___ Fixture(s)	63	Water piping replacement branch/fixture	___ Fixture(s)
27	Pressure regulator—prv/water	___ Device(s)	64	Other water piping < 1 1/2 inches	___ Line(s)
29	Roof drains	___ Fixture(s)	65	Other water piping 2-3 inches	___ Line(s)
35	Solar water heating system	___ System(s)	66	Other water piping > 3 inches	___ Line(s)
39	Swimming pool trap and receptor	___ System(s)			
41	Trap primer	___ System(s)			

## MECHANICAL

Code	Items	Units	Code	Items	Units
02	Refrig compressor < 100 kbtu	___ Comp(s)	31	Air inlets/outlets (area)	___ Sq. Ft.
03	Refrig compressor 101—500 kbtu	___ Comp(s)	32	Appliance vent (other)	___ Unit(s)
04	Refrig compressor > 500 kbtu	___ Comp(s)	35	Air handling unit < 2000 cfm	___ Ahu(s)
08	Furnace/heater <100 kbtu	___ Unit(s)	36	Air handling unit 2000—10000 cfm	___ Ahu(s)
09	Furnace/heater 101-500 kbtu	___ Unit(s)	37	Air handling unit > 10000 cfm	___ Ahu(s)
10	Furnace/heater > 500 kbtu	___ Unit(s)	40	Evaporative coolers	___ Unit(s)
17	Boiler < 100 kbtu	___ Boiler(s)	41	Ventilation fan (single register)	___ Fan(s)
18	Boiler 101-500 kbtu	___ Boiler(s)	42	Ventilation system (other)	___ System(s)
19	Boiler > 500 kbtu	___ Boiler(s)	43	Commercial kitchen exhaust hoods	___ Hood(s)
20	Fireplace/gas log < 100 kbtu	___ Appl(s)	44	Spray booth	___ Booth(s)
21	Fireplace/gas log 101-500 kbtu	___ Appl(s)	45	Product conveying duct system	___ System(s)
22	Fireplace/gas log > 500 kbtu	___ Appl(s)	46	Fire dampers	___ Damper(s)
30	Air inlets/outlets (each)	___ Unit(s)	47	Alteration of existing duct system	___ System(s)

## ELECTRICAL

Code	Items	Quantity	Code	Item	Quantity	Code	Item	Quantity		
B1	Residential new bldgs. Multifamily	___ Sq. Ft.								
B2	Residential new bldgs. 1 or 2 family	___ Sq. Ft.								
C1	Swimming pools, new	___ Pool(s)	K1	Signs, outline lgt, one ckt	___ Sign(s)	JX	Motors, <3hp	___ Mtr(s)		
C2	Spas, hot tubs,	___ Pool(s)	K2	Additnl, ckt within the same sign	___ Sign(s)	JY	Motors, 5hp	___ Mtr(s)		
C3	Pool alterations, other type pools	___ Pool(s)	<u>Power Equipment Over 3hp and Less Than 10hp</u>					JZ	Motors, 10hp	___ Mtr(s)
D1	Carnival electrical rides or genrtrs	___ Unit(s)	JA	Heat pumps	___ Appl(s)	J0	Motors, 15hp	___ Mtr(s)		
D2	Carnival mech rides, displays w/lgt	___ Unit(s)	JB	AC units	___ Appl(s)	J1	Motors, 20hp	___ Mtr(s)		
D3	Carnival booth lighting	___ Unit(s)	JD	Battery chargers	___ Appl(s)	J2	Motors, 25hp	___ Mtr(s)		
E1	Temporary service, power pole	___ Pole(s)	JE	Electric water heaters	___ Appl(s)	J3	Motors, 50hp	___ Mtr(s)		
E2	Temporary dist system for const	___ Unit(s)	JF	Refrigeration cabinets	___ Appl(s)	J4	Motors, 100hp	___ Mtr(s)		
E3	Temp pole for xmas tree lots	___ Pole(s)	JG	Electric cooking equipment	___ Appl(s)	<u>Other Power Equipment</u>				
F1	Branch circuits, 120v, 15 or 20a	___ Ckt(s)	JH	Electric heaters	___ Appl(s)	J7	Pwr eq w/rating > 10hp to <50hp	___ Pwr		
F2	Branch circuits, lighting, 208-277v	___ Ckt(s)	JI	Electric generators	___ Appl(s)	J8	Pwr eq w/rating > 50hp to <100hp	___ Pwr		
G1	Outlets-lighting, recept, switch	___ Outlet(s)	J6	Other equipment > 3hp—<10hp	___ Appl(s)	J9	Pwr eq w/rating > 100hp	___ Pwr		
G2	Lighting fixtures	___ Lgt Ftx(s)	<u>Special Electrical Items</u>					<u>Services, Panels, Control Panels, Mcc's</u>		
G3	Pole mounting light fixtures	___ Pole Fxt(s)	P2	PC residential photo voltaic<10kw	___	LA	100a panels, services, mcc's	___ Pnl(s)		
G4	Theatrical-type lgt fixtures	___ Lgt Ftx(s)	P3	Inverter res photo volt <10kw	___	LB	200a panels, services, mcc's	___ Pnl(s)		
<u>Residential Appliances Less Than 3hp</u>			P4	PC residential photo volt >10kw<50kw	___	LC	225a panels, services, mcc's	___ Pnl(s)		
HA	Forced air units (FAU)	___ Appl(s)	P5	Inverter res photo volt >10kw<50kw	___	LD	400a panels, services, mcc's	___ Pnl(s)		
H1	Electrical ovens	___ Appl(s)	V2	<=10kw electric vehicle supply equip	___ #Units	LE	600a panels, services, mcc's	___ Pnl(s)		
H2	Garbage disposals	___ Appl(s)	V3	>10kw electric vehicle suppl equip	___ #Units	LF	800a panels, services, mcc's	___ Pnl(s)		
H3	Dishwashers	___ Appl(s)	V4	Fast electric vehicle suppl equip	___ #Units	LG	1000a panels, services, mcc's	___ Pnl(s)		
H4	Range hoods	___ Appl(s)	<u>Transformers</u>					LH	1200a panels, services, mcc's	___ Pnl(s)
H5	Washing machines	___ Appl(s)	JM	Transformers, <3kva	___ Xfmr(s)	LI	1600a panels, services, mcc's	___ Pnl(s)		
H7	Exhaust fans	___ Appl(s)	JN	Transformers, 15kva	___ Xfmr(s)	LJ	2000a panels, services, mcc's	___ Pnl(s)		
H9	Other residential less than 3hp	___ Appl(s)	JO	Transformers, 25kva	___ Xfmr(s)	LL	3000a panels, services, mcc's	___ Pnl(s)		
<u>Non Residential Appliances Less Than 3hp</u>			JQ	Transformers, 37.5kva	___ Xfmr(s)	LM	High voltage panels (over 600v)	___ Pnl(s)		
1A	Exhaust fans	___ Appl(s)	JR	Transformers, 45kva	___ Xfmr(s)	LN	Other panels, 0 to 399 amps	___ Pnl(s)		
1B	Electric water heaters	___ Appl(s)	JS	Transformers, 50kva	___ Xfmr(s)	LO	Other panels, 400 to 1000 amps	___ Pnl(s)		
1C	Lighted showcases	___ Appl(s)	JT	Transformers, 75kva	___ Xfmr(s)	LP	Other panels, >1000 amps	___ Pnl(s)		
1D	Electric drinking fountains	___ Appl(s)	JU	Transformers, 112.5kva	___ Xfmr(s)	W1	Cable trays, busways (length)	___ Feet		
1E	Vending machines	___ Appl(s)	JV	Transformers, 150kva	___ Xfmr(s)	M1	Misc conduits & conductors	___ Unit(s)		
1F	Laundry machines	___ Appl(s)	JW	Transformers, 225kva	___ Xfmr(s)	P1	Haz locations >2000 sf total	___ Haz		
J5	Other non-res less than 3hp	___ Appl(s)				R1	Report review fee, # of equip	___ Eq		
						R2	High voltage report fee, #equip	___ HV Eq		

JOB ADDRESS
LOCALITY

**COLUMN 1**

**OWNER-BUILDER DECLARATION**

I hereby affirm under penalty of perjury that I am exempt from the Contractors' State License Law for the reason(s) indicated below by the checkmark(s) I have placed next to the applicable item(s) (Section 7031.5, Business and Professions Code): Any city or county that requires a permit to construct, alter, improve, demolish, or repair any structure, prior to its issuance, also requires the applicant for the permit to file a signed statement that he or she is licensed pursuant to the provisions of the Contractors' State License Law (Chapter 9 (commencing with Section 7000) of Division 3 of the Business and Professions Code) or that he or she is exempt from licensure and the basis for the alleged exemption. Any violation of Section 7031.5 by any applicant for a permit subjects the applicant to a civil penalty of not more than five hundred dollars (\$500.)

() I, as owner of the property, or my employees with wages as their sole compensation, will do () all of or () portions of the work, and the structure is not intended or offered for sale (Section 7044, Business and Professions Code: The Contractors' State License Law does not apply to an owner of property who, through employees' or personal effort, builds or improves the property, provided that the improvements are not intended or offered for sale. If, however, the building or improvement is sold within one year of completion, the Owner-Builder will have the burden of proving that it was not built or improved for the purpose of sale.)

() I, as owner of the property, am exclusively contracting with licensed Contractors to construct the project (Section 7044, Business and Professions Code. The Contractor's State License Law does not apply to an owner of property who builds or improves thereon, and who contractors for the projects with a license Contractor pursuant to the Contractors' State License Law.)

() I am exempt from licensure under the Contractors' State License Law for the following reason:

\_\_\_\_\_

By my signature below I acknowledge that, except for my personal residence in which I must have resided for at least one year prior to completion of the improvements covered by this permit, I cannot legally sell a structure that I have built as an owner-builder if it has not been constructed in its entirety by licensed contractors. I understand that a copy of the applicable law, Section 7044 of the Business and Professions Code, is available upon request when this application is submitted or at the following Web site: <http://www.leginfo.ca.gov/calaw.html>.

Date: \_\_\_\_\_

\_\_\_\_\_  
Signature of Property Owner or Authorized Agent

**COLUMN 2**

**LICENSED CONTRACTOR'S DECLARATION**

I hereby affirm under penalty of perjury that I am licensed under provisions of Chapter 9 (commencing with Section 7000) of Division 3 of the Business and Professions Code, and my license is in full force and effect.

License Class \_\_\_\_\_ License No. \_\_\_\_\_

Date \_\_\_\_\_ Contractor Signature \_\_\_\_\_

**WORKERS' COMPENSATION DECLARATION**

**WARNING: FAILURE TO SECURE WORKER'S COMPENSATION COVERAGE IS UNLAWFUL AND SHALL SUBJECT AN EMPLOYER TO CRIMINAL PENALTIES AND CIVIL FINES UP TO ONE HUNDRED THOUSAND DOLLARS (\$100,000), IN ADDITION TO THE COST OF COMPENSATION, DAMAGES ARE PROVIDED FOR IN SECTION 3706 OF THE LABOR CODE, INTEREST, AND ATTORNEY'S FEES.**

I hereby affirm under penalty of perjury one of the following declarations:

I have and will maintain a certificate of consent to self-insure for workers' compensation, issued by the Director of Industrial Relations as provided for by Section 3700 of the Labor Code, for the performance of the work for which this permit is issued.

Policy No. \_\_\_\_\_

I have and will maintain workers' compensation insurance, as required by Section 3700 of the Labor Code, for the performance of the work for which this permit is issued. My workers' compensation insurance carrier and policy number are:

Carrier	Policy Number	Expiration Date
_____	_____	_____

Name of Agent	Phone Number
_____	_____

I certify that, in the performance of the work for which this permit is issued, I shall not employ any person in any manner so as to become subject to the workers' compensation laws of California, and agree that, if I should become subject to the workers' compensation provisions of Section 3700 of the Labor Code, I shall forthwith comply with those provisions

\_\_\_\_\_  
Signature of Applicant

\_\_\_\_\_  
Date

**COLUMN 3**

**HAZARDOUS MATERIAL DECLARATION**

Will the applicant or future building occupant handle a hazardous material or a mixture containing a hazardous material equal to or greater than the amount specified on the hazardous material information guide?

Yes  No

Will the intended use of the building by the applicant or future building occupant require a permit for construction or modification from the South Coast Air Quality Management District (SCAQMD)? See permitting checklist for guidelines.

Yes  No

I have read the hazardous materials information guide and the SCAQMD permitting checklist. I understand my requirements under the Los Angeles County Code Title 2, Chapter 220 Sections 220.100 through 220.140 concerning hazardous material reporting and for obtaining a permit from the SCAQMD.

**ASBESTOS NOTIFICATION**

Notification letter sent to SCAQMD or EPA

I declare that notification of asbestos removal is not applicable to addressed project.

**DECLARATION REGARDING CONSTRUCTION LENDING AGENCY**

I hereby affirm under penalty of perjury that there is a Construction lending agency for the performance of the work for which this permit is issued (Section 3097, Civil Code)

\_\_\_\_\_  
Lender's Name

\_\_\_\_\_  
Lender's Address

By my signature below, I certify to each of the following:  
I am the property owner or authorized to act on the property owner's behalf.

I have read this application and the information I have provided is correct.

I agree to comply with all applicable city and county ordinances and state laws relating to building construction.

I authorize representatives of this county to enter the above-identified property for inspection purposes.

\_\_\_\_\_  
Signature of Property Owner or Authorized Agent

\_\_\_\_\_  
Date